

Leeds Scottish Country Dance Club 29 September 2018

Music: George Meikle MC: Veronica Hughes

1 THE CRANBERRY TART J32 · 3/4L

Terry Glasspool: Dances from the Seven Year Itch · Crib: MiniCribs · Diagram: Keith Rose's Diagrams

- 1-8** 1M sets & casts 1 place, sets & petronella turns between 3s facing up **while** 1L stands for 2 bars then sets, casts 1 place & sets
- 9-16** 1M sets in line with 3s & all 3 Adv+Ret then 1M advances to partner **while** 1L petronella turns between 2s & sets in line with 2s then all 3 Adv+Ret
- 17-24** 1L followed by partner dances reel of 3 across with 2s (RSh to 2L) to end in 2nd place own sides
- 25-32** 1s dance RSh reels of 3 on sides giving RSh to 3s

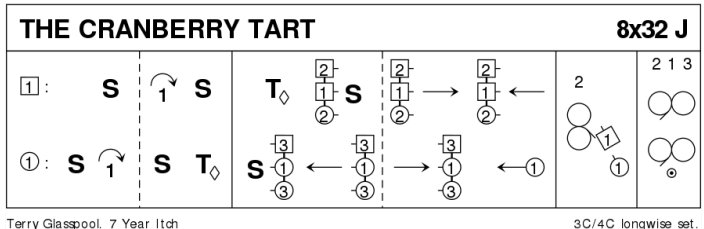

2 THE SUMMER ASSEMBLY R88 · 4S

Roy Goldring: RSCDS XXXV 8 · Crib: MiniCribs · Diagram: Keith Rose's Diagrams

- 1-16** All turn RH & Ladies dance on 1 place clockwise & all set to new partners, turn new prttrs RH, Ladies dance on 1 pl (pass RSh) & set to new prttrs
- 17-32** Repeat bars 1-16 but all turn LH & Men dancing on anticlockwise (pass LSh)
- 33-48** 1s+3s dance RH across then 1M & 3M followed by ptnrs dance cl'wise round outside of set back to original places 2nd & 4th couples repeat
- 49-56** All Ladies dance Figs of 8 round their partners & corners (start by passing in front of partners)
- 57-64** All Men dance Figs of 8 round their partners & corners (start by passing in front of partners)
- 65-80** 1s+3s change places (3s making an arch) & set, repeat back to places with 1s making the arch, 2nd & 4th repeat (4s make 1st arch)
- 81-88** All circle 8H round & back

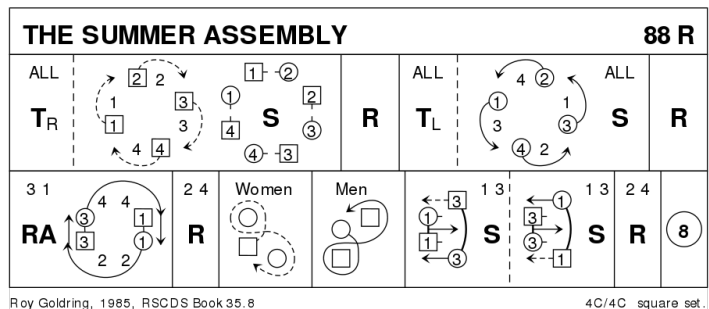

3 MISS ELEANOR S32 · 3/3L

Ann Dix: RSCDS XLIX 5 · Crib: MiniCribbs · Diagram: Keith Rose's Diagrams

- 1-8 1s+2s+3s dance Mirror (Reflection) reels of 3 on sides (1s in/down to start)
- 9-16 1s set, cast (2s step up) & turn RH. 1L casts to 3rd place, 1M casts up to 1st place (2M steps down & 3L steps up)
- 17-24 All dance 3 couple Bourrel:
 17-20 1M+3L also 2M+1L set advcg & 3/4 turn 2H to line up/down middle then pull back RSh turning to face own prttrs as 3M & 2L chase anticl'wise to face them
 21-24 All set & turn 2H to own sides. 3 1 2
- 25-32 3s+1s+2s circle 6H round & back

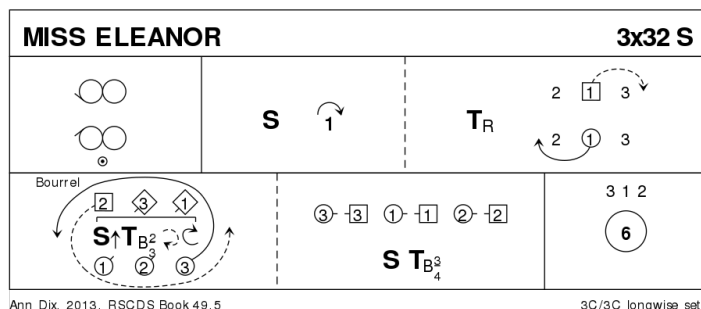

4 THE LAST OF THE LAIRDS J32 · 3/4L

Hugh A Thurston: RSCDS XXII 5 · Crib: MiniCribbs · Diagram: Keith Rose's Diagrams

- 1-8 1s cross down (each couple cross down as they reach top place) to dance reflection reels of 3 on sides
- 9-16 1s cross down (each couple cross down as they reach top place) to dance reflection reels of 3 on sides
- 17-24 1s set & cross RH then cast 1 place, cross down between 3s & cast up to 2nd place on own sides
- 25-32 1s lead up between 2s & cast down 1 place, 2s+1s+3s turn RH

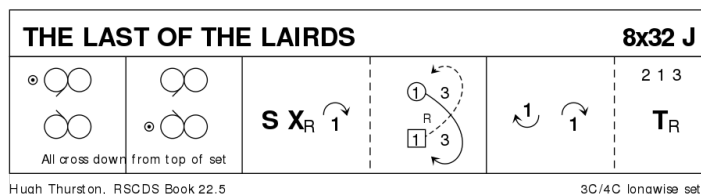

5 THE MORRISON MEASURE R32 · 5/5L

Roy Goldring: A Reel for Alice and Other Social Dances · Crib: MiniCribbs · Diagram: Keith Rose's Diagrams

- 1-8 1s dance RSh reels of 3 on own sides
- 9-16 1L followed by partner casts to 3rd place (2s+3s up) & crosses to opposite side, 3s+1s dance RH across
- 17-24 1s dance LSh reels of 3 on opposite sides with 4s+5s
- 25-32 1L followed by partner casts to bottom & crosses to own side, 5s+1s dance LH across

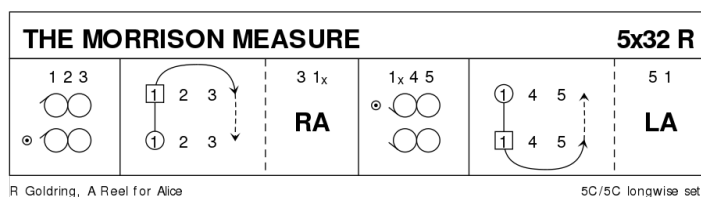

6 THE GARRY STRATHSPEY S32 · 4/4L

James B Cosh: Twenty Two SCD · Crib: MiniCribs · Diagram: Keith Rose's Diagrams

- 1-8** 1s+2s & 3s+4s dance 1/2 R&L, 1s+4s (in centre) dance 1/2 R&L
- 9-16** 2s+4s & 1s+3s circle 4H left 1/2 way, 2s+3s circle 4H right 1/2 way, 1s dance up to top & all face as for Reel of 4 on sides
- 17-24** All set HS & dance 1/2 Grand Chain
- 25-32** All dance Reel of 4 on sides. 2 3 4 1

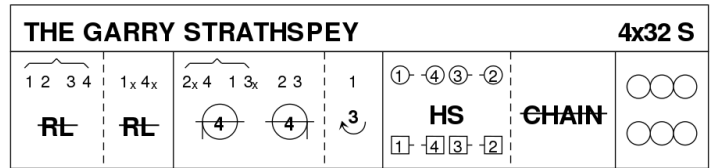

7 SETON'S CEILIDH BAND J64 · 4/4L

A Bruce Fordyce: The Bruce Fordyce Memorial Collection · Crib: MiniCribs · Diagram: Keith Rose's Diagrams

- 1-8** 1s cross RH & cast 1 place (2 step up), dance down between 3s (3s step up) & cast down behind 4s to 4th place (4s step up)
- 9-16** 1s dance reflection reels of 3 on opposite sides (1s in/up, 4s out/down)
- 17-24** 1s cross RH & cast up 1 place, lead up between 3s & cast up behind 2s to 1st place own sides
- 25-32** 1s dance reflection reels of 3 on own sides (1s in down, 2s out/up)
- 33-40** 1s cross RH & cast down 1 place (2 step up) 1s give RH to partner & LH to 1st corners, Bal-in-Line & turn partner RH to give LH to 2nd corners
- 41-48** Bal-in-Line & 1s dance out & cast down behind 3s, meet & lead up to top crossing to 1st place own sides (2s step down)
- 49-60** 1L+2L & 1M+2M change places RH on sides & 2s+1s cross over LH, repeat with 3s & 4s until reaching the bottom of the set
- 61-64** All turn partners RH 1.1/2 times

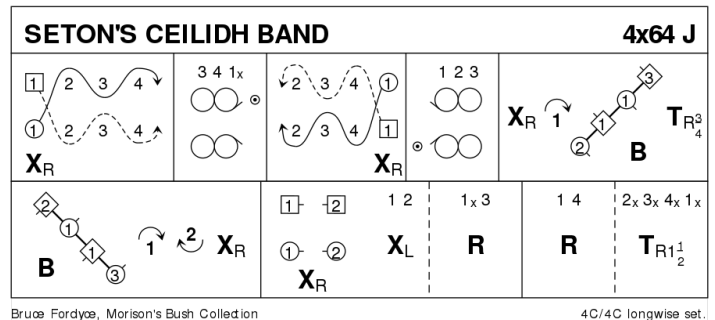

8 GLASTONBURY TOR R32 · 3/4L

Duncan Brown: RSCDS XLVII 11 · Crib: MiniCribs · Diagram: Keith Rose's Diagrams

- 1-8** 1s+2s set & dance 1/2 RH across, 1s+3s set & dance 1/2 LH across
- 9-16** 1s set & cross RH, 1s cast up 1 place & turn LH turn to face 1st corners (pstns)
- 17-20** 1s dance 1/2 reel of 4 with 1st cnrns (pstns) & pass left to face 2nd cnrns (pstns)
- 21-24** 1s dance 1/2 reel of 4 with 2nd cnrns (pstns) & curve right to end 1M between 3s facing down & 1L btwn 2s facing up
- 25-32** 1M+3s also 1L +2s Set+Link for 3 once, 1s turn RH 1.1/2 times to 2nd place as 2s & 3s dance clockwise 1/2 way to places 2 1 3

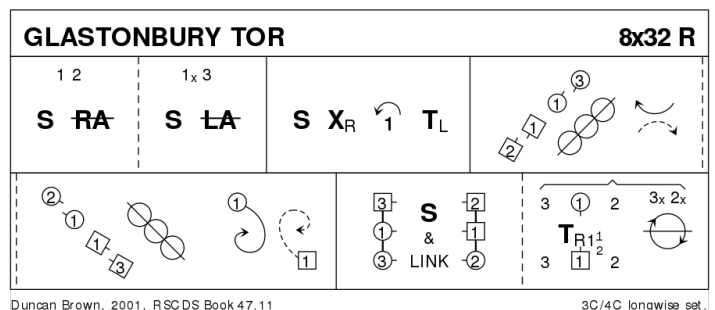

9 PROGRAMME ITEM – Interval

10 AIRD OF COIGACH J48 · 4/4L

John Bayly: *Imperial Book of Scottish Country Dances - Volumes 1-3 · Crib: MiniCribs · Diagram: Keith Rose's Diagrams*

- 1-8** All Men dance across passing partner RSh & cast down to the bottom of set (4th Man leading), cross the bottom of the set & up Men's side
- 9-16** All circle 8H round & back (retaining the circle formation to bar 40)
- 17-20** 1s with dancers on their left (1M+2M & 1L+2L) NHJ cross diagonally (Men's arch) & both pairs turn away from each other to face in
- 21-24** 1s with dancers on their left (1M+3L & 1L+3M) NHJ cross over (1M+3L make arch) both pairs turning away from each other to face in
- 25-32** 1s continue this Fig 2 more times to end with top 2 dancers facing each other also bottom dancers facing each other for a Snowball Grand Chain
- 33-40** All dance Snowball Grand Chain for 4 cpls:
End couples cross RH & change places LH on side with side persons
Original side persons cross RH **while** original end couples change places RH on sides & all change places LH on sides
- 41-48** All Ladies dance across passing opposite Man RSh & cast up to top, cross & down on the Ladies' side to end opposite partner. 2 3 4 1

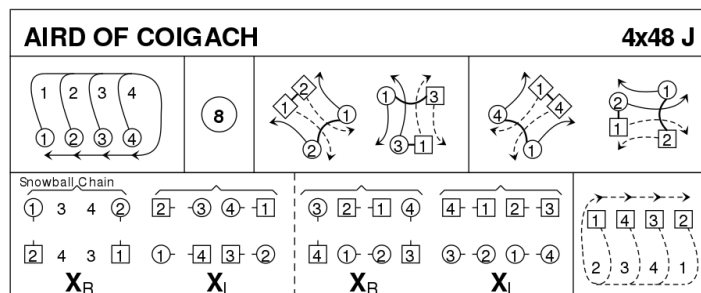

John Bayly, 1975, Imperial Book 3.13

4C/4C longwise set.

11 MRS MACPHERSON OF INVERAN R32 · 3/4L

John Drewry: *Bon Accord Book of Scottish Country Dances · Crib: MiniCribs · Diagram: Keith Rose's Diagrams*

- 1-8** 1s dance Inveran Reels with 2s+3s
- 9-16** 1s turn RH 1.1/2 times moving down to 2nd places (opposite sides), 1s cast up behind 2s & cross down to 2nd place own side
- 17-24** 2s+1s+3s dance Grand Chain
- 25-32** 2s+1s+3s circle 6H round & back

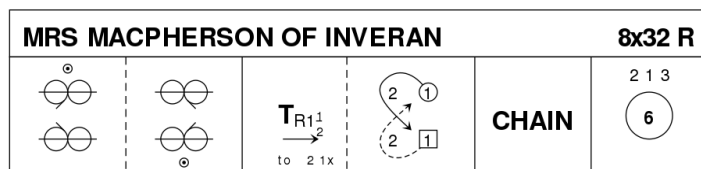

John Drewry, 1964, Bon Accord Book

3C/4C longwise set.

12 ALISON ROSE S32 · 4/4L

Derek Ivory: *Imperial Book of Scottish Country Dances - Volumes 1-3 · Crib: MiniCribbs · Diagram: Keith Rose's Diagrams*

- 1-8** 1s lead down to bottom, all set & circle 8H round to left 2 places (end with Men at top of dance & Ladies at bottom)
- 9-16** Men dance LH across & Ladies RH across once round, continue but change places with partner when passing thru middle in order 1 4 3 2
- 17-24** As 1s (+4s+3s+2s) meet again (Men drop RH) & leads his prtnr round to end 1s (followed by 4s+3s+2s) leading up to top, all 1/2 turning RH into...
- 25-32** All dance Allemande ending 2 3 4 1

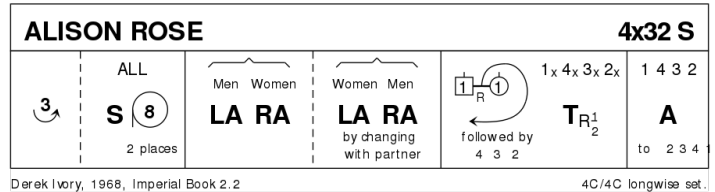

13 THE FIRST RAIN OF SPRING J32 · 3/3L

Wouter Joubert: *RSCDS XLIX 4 · Crib: MiniCribbs · Diagram: Keith Rose's Diagrams*

- 1-8** 1s dance down, cast up round 3s, meet, dance up to 1st place facing out. 1s+2s 1/2 turn (Men LH, Ladies RH)
- 9-16** 2s+1s dance double Figs 8 (1s cross up, 2s cast to start)
- 17-20** 1s+3s 3/4 turn RH into line up/down in middle facing partner & set
- 21-28** 1s+3s dance 1/2 Celtic Reel:
21-22 1s+3s pass partner RSh
23-24 1M+3L dance clockwise **while**
 1L+3M dance 3/4 round each other LSh to face partners in line across
25-26 1s+3s pass partner RSh
27-28 1L+3M dance clockwise **while** 1M+3L dance 3/4 round each other LSh to face partners in line up/down set
- 29-32** 3s+1s 3/4 turn partners RH to sidelines & 2s+3s+1s set

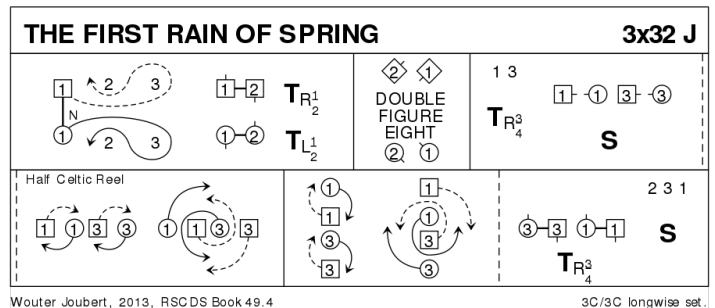

14 NEVER AT SEA R48 · 6/6L

J C Haddow: *Scottish Country Dances in Diagrams. Ed. 9 · Crib: MiniCribbs · Diagram: Keith Rose's Diagrams*

4s & 5s & 6s start on opp sides

- 1-8** 1s cross RH & cast to 2nd place, cross LH & cast to 3rd place **while** 6s cross RH & cast to 5th place, cross LH & cast to 4th place
- 9-16** 1M+6L Prom hold dance reel of 3 with 4s (pass 4M LSh to start) **while** 6M+1L dance reel of 3 with 3s (pass 3M LSh) end 1s in 3rd place side by side facing up & 6s in 4th place facing down ready for:..
- 17-24** 1s & 6s dance reflection reels on sides dancing up/down between 3s/4s to start
- 25-32** 1s+6s dance R&L ending with 1s facing up & 6s facing down
- 33-36** End couples cross RH **while** cpl in 2nd+3rd pl also cpl in 4th+5th pl dance 1/2 RH across & all (1st+2nd pl, 3rd+4th pl, 5th+6th pl) change pl LH on side
- 37-40** Repeat bars 33-36
- 40-44** Repeat bars 33-36
- 45-48** All turn partners RH 5 4 6(1)(3)(2)

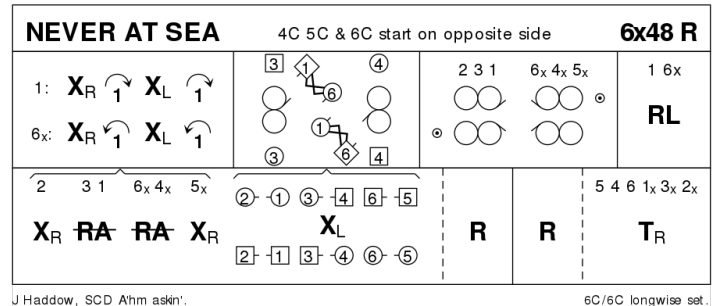

Dance 3 times to end 6 5 4(3)(2)(1) or 6 times to end 1 2 3(4)(5)(6)

15 CHERRYBANK GARDENS S32 · 3/3L

John Drewry: *Bankhead Book Part 1 · Crib: MiniCribbs · Diagram: Keith Rose's Diagrams*

- 1-8** 1s+2s set & Petronella-in-tandem twice to end with 2s+1s on opposite sides having changed places
- 9-16** 2s+1s set & 2s cross RH & 1s LH, 1L dances RH across with 2s & 1M with 3s
- 17-24** 1s+3s Set+Link & circle 4H round to left
- 25-32** 2s+3s+1s dance Grand Chain (2s crossing to commence)

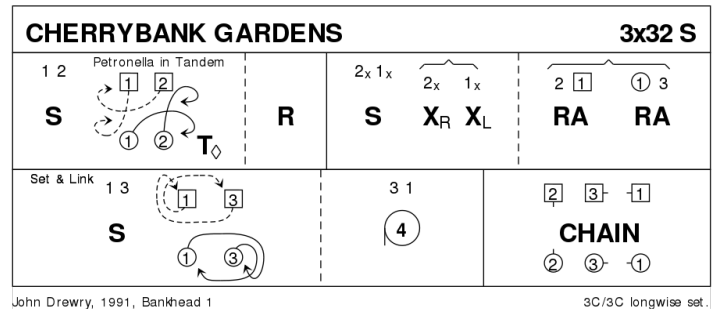

16 PELORUS JACK J32 · 3/4L

Barry Skelton: *RSCDS XLI 1 · Crib: MiniCribbs · Diagram: Keith Rose's Diagrams*

- 1-8** 1s cross RH & cast 1 place, dance RH across with 3s. 1s end with Man facing his 1st corner with his partner behind him
- 9-16** 1s dance Alternating Tandem 1/2 reel of 3 with 1st corners to face Man's 2nd corner, 1s dance Alternating Tandem 1/2 reel of 3 with 2nd corners
- 17-24** 1s dance Alternating Tandem 1/2 reels of 3 with Ladies' 1st corner (pstin), 1s dance Alternating Tandem 1/2 reel with Ladies' 2nd corner (pstin)
- 25-32** 1M followed by partner dance into LH across with 2s, 1s retain LH & 1/2 turn to own sides & 2s+1s+3s set

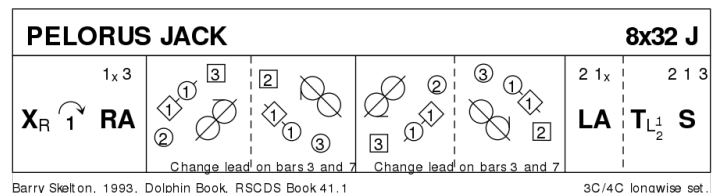

17 THE PIPER AND THE PENGUIN

R88 - 4S

Roy Goldring: *The Scotia Suite of Scottish Country Dances* · Crib: *MiniCribs* · Diagram: *Keith Rose's Diagrams*

- 1-8** Ladies dance RSh round their corners, dance RH across ending in centre
- 9-16** Ladies dance LSh round their partners, dance LH across & back to places
- 17-24** Men dance RSh round their partners, dance RH across ending in centre
- 25-32** Men dance LSh round corners, dance LH across & back to places
- 33-40** 1s & 3s turn partners RH 1.1/4 times, Men followed by partners dance out between side couples & back to places (1M thru 4s & 3M thru 2s)
- 41-48** 1s+3s dance R&L
- 49-56** 2s & 4s turn partners RH 1.1/4 times, Men followed by partners dance out between side couples & back to places (2M thru 1s & 4M thru 3s)
- 57-64** 2s+4s dance R&L
- 65-72** Ladies dance in turning right about to dance out, cast clockwise to opposite Lady's place
- 73-80** Men dance in turning left about to dance out, cast anticlockwise to opposite places
- 81-88** All turn partners RH 1.1/4 times into prom hold, Promenade anticlockwise 1/2 way round to original places

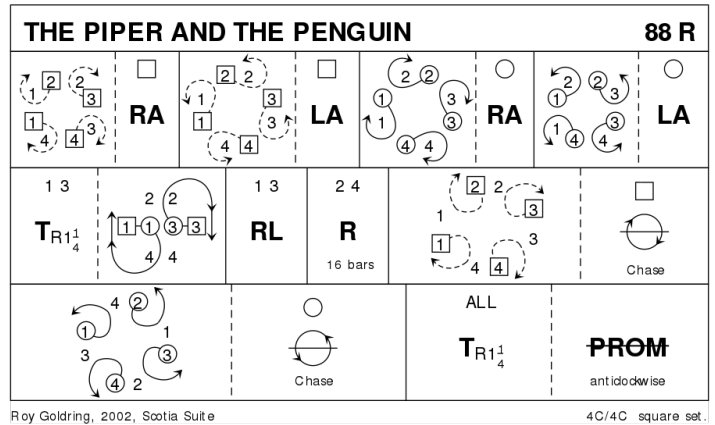

18 PROGRAMME ITEM – Extras

19 ARGYLLS' FAREWELL TO STIRLING

R40 - 4/4L

Keith W Dingley: *Bannockburn 700* · Crib: *MiniCribs* · Diagram: *Keith Rose's Diagrams*

- 1-8** 1M+2M+3M turn 2L+3L+4L RH & turn partners LH
- 9-16** 1s+2s+3s slip step down for 2 bars & 1/2 turn, slip step up to top & 1/2 turn to places
- 17-24** 1s+2s dance R&L
- 25-32** 1M followed by partner casts 1 place & crosses to opposite side to dance RH across with 3s
- 33-40** 1M followed by partner cast on opposite side to 4th place & crosses to own side to dance RH across with 4s

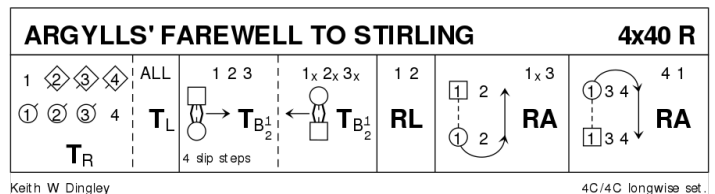

20 ROUND REEL OF EIGHT R88 · 4S

RSCDS XXVII 7 · Crib: MiniCribs · Diagram: Keith Rose's Diagrams

- 1-16** All Ladies cast & dance clockwise round outside of set back to place, Men repeat Fig but cast & dance anticlockwise round set
- 17-32** All dance Grand Chain 1/2 way & set to partner, continue Chain back to place & set to partner
- 33-40** 1s+3s change places 1s dance between 3s, repeat Fig back to places 3s dance between 1s & 1s+3s turn RH into Allemande hold
- 41-48** 1s+3s dance round inside of set anticlockwise in Allemande hold
- 49-64** 2s+4s repeat Fig bars 33-48
- 65-88** 1s+3s dance 1/2 R&L, 2s+4s dance 1/2 R&L, repeat back to places, all circle 8H round & back

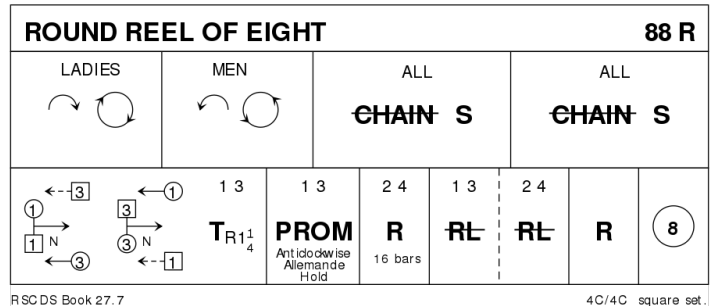

21 SPIFFIN' J32 · 5S

Quarries and Friends: Chicago 25th Anniversary Collection · Crib: MiniCribs · Diagram: Keith Rose's Diagrams

- 1-8** 5s dance reels of 3 with 1s+3s (5s start by passing opposite dancer by LSh)
- 9-16** 5L dances RH across with 2s **while** 5M dances LH across with 4s, 5s lead up thru 1s & cast back to centre
- 17-24** 5L dances LH across with 2s **while** 5M dances RH across with 4s, 5s lead down thru 3s & cast back to centre
- 25-32** 5s Tulloch turn right (Kilt Grip) twice, 5s+1s set & dance part LH across (5s dance 1/2 way **while** 1s dance 1/4 way & into centre to face 2s)

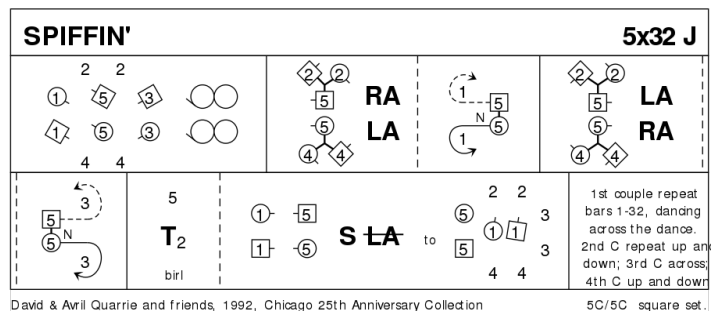

22 INDIAN RIVER STRATHSPEY S32 · 3T

George Senyk: Scottish Country Dances in Diagrams. Ed. 9 · Crib: MiniCribs · Diagram: Keith Rose's Diagrams

- 1-8** 1s+2s+3s in prom hold dance a reel of 3 across the set, 1s passing 3s RSh to start
- 9-16** 1s (with Lady leading) dance RH across with 3s & dance LH across with 2s
- 17-24** 2s+3s dance Ladies Chain across the set **while** 1s set (2 bars) & then dance between 2s+3s & cast individually back to places
- 25-32** 1s+3s dance 1/2 R&L, 1s+2s dance 1/2 R&L to end 3 1 2

